

LabVIEW based Sliding Mode Control of a pH Neutralization System

S.Harivardhagini

CVR College of Engineering, EIE Department, Hyderabad, India

Email: harivardhagini@gmail.com

Abstract— This paper targets at designing a control mechanism using the method of Variable Structure Control [VSC] for a pH neutralization process plant. This VSC involves SLIDING MODE CONTROL (SMC). The prototype pH model involves acidic and alkaline reagent solutions which in proper quantities are mixed into a Continuous Stirred Tank Reactor [CSTR] in proper proportions. The pH of the plant is in turn controlled by the same. The flow rate of acid and alkaline solutions is controlled by the control mechanism. SMC is a type of nonlinear control. The pH neutralization process is a best example of non linear system; hence SMC offers a better solution. SMC suffers a problem called chattering, to overcome this, Dynamic Sliding Mode controller can be implemented. LabVIEW software is used to implement the controller. LabVIEW is the acronym for Laboratory Virtual Instrumentation Workbench. The prototype model is subjected to this programming method and the results are presented. This is a graphical programming technique. The interfacing of the software and the prototype hardware is done using DAQs.

Index Terms-- Variable Structure Control, Sliding Mode Control, Ph Control, LabVIEW

I. INTRODUCTION

Contaminants such as organic substances, heavy metals, suspended solids and cyanides are present in wastewater from several industries. This poses potential health risks and also its hazardous to public and environment. The techniques used in the convention treatment of wastewater involve precipitation of heavy metals, flocculation, settling and discharge [1]. Apart from addition of chemicals, the treatment involves adjustment of pH also. This makes pH control a highly non linear process [2]. By manipulating an acid and an alkaline stream the pH is monitored and controlled. Several modern treatment processes use both physical and chemical precipitations where neutralization of pH is the prime factor for effective treatment. A pH sensor is used in most processes for the on-line measurement and control. In this paper, LabVIEW software is used to operate and control the system automatically by an online computer. Frequent load changes and severe non linearities make the pH control in a wastewater treatment process very difficult [3]. The primary source of the non-linearity is the S – shaped titration curve. In this paper using VSC, a possible better control of pH in a wastewater treatment process is suggested. To indicate the robustness of VSC few studies have been done in the non linear control area [4].

A. Variable Structure Control [VSC]

SMC is a type of Variable Structure Control (VSC). In control system engineering theory, SMC, is a type of a non linear method which applies a discontinuous signal to the process and in turn alters its dynamics. This in turn forces the system to "slide" on a surface which is equivalent to the systems general behavior [5]. In SMC, the control law governing the system is not a continuous function of time. Still depending on the present position it can switch from one continuous control structure to another continuous control structure in their corresponding state space. Because of the above mentioned characteristic, the SMC is considered as a robust controller which can overcome the problems of non linearity [6]. Several control structures are designed in such a way that the trajectories move to towards nearby regions, thereby resulting in having a trajectory with different control structures. This trajectory will tend to slide along the borders of the control structures. Sliding mode term is used due to this movement of the system, as it slides along these boundaries. The sliding (hyper) surface is the locus consisting of the sliding mode boundaries. So we have a flexibility of having a system with different control structures but with a common trajectory.

Fig. 1 represents the sliding surface of a system with the trajectories. $s=0$, is the equation representing the sliding surface, also the sliding begins after the trajectories reach the common surface after a finite time. Practically the sliding occurs the control signal incurs high frequency switching and this causes the system to CHATTER in its adjacent control structures [7]. From the figure it can be seen that the system is subjected to chattering phenomenon. Although it experiences chattering asymptotically it reaches origin [8]. This response makes the system act like a linear control system. Though the system is non linear, but when it confines to the surface $s=0$, it exhibits the idealized (i.e., non-chattering) behavior with a stable origin. An infinite gain is used to force the trajectories to slide along the subspace of the sliding area [9]. Using reduced-order sliding mode, the systems obtains desirable properties such as, allowing the system to slide smoothly along its trajectories until it reaches its desired equilibrium. As the switching involves transfer between two states i.e. ON/OFF, the parameter disturbances does not affect the performance of the controller. This property of this controller makes it more robust.

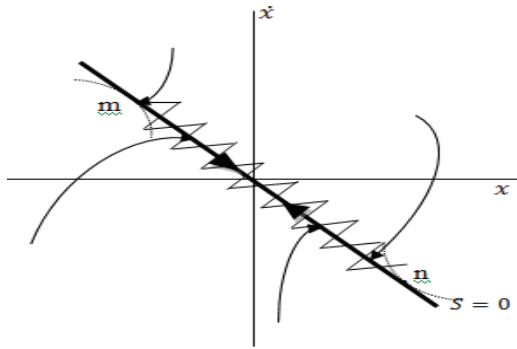

Figure 1. Example of a Sliding Surface

Also the controller need not be precise as it is only the switching between two states and the intermediate points are not considered. As the control law defined is not a continuous function, it makes the sliding mode reach the equilibrium in a *finite* time. This makes the system behave better than asymptotic response. Due to this behavior SMC is suited as an optimal controller for several dynamic systems. One application of SMC is the electric drives control which is operated by using switching power converters. Other applications of SMC include robotics. Specific applications includes, tracking control of unmanned surface vessels with good degree of success in simulated rough seas. Compared to non linear control actions that have moderate control actions more care must be applied to Sliding mode control. Few equipments like actuators incur delays and few other imperfections, which leads the sliding mode control to result in effects such as chattering, energy losses excitation of several un-modeled dynamics and plant damage. Continuous Control Design (CCD) methods are advantageous as they are not as prone to such problems and hence can be made to replicate SMC.

II. THE PH NEUTRALIZATION PROTOTYPE SYSTEM

A. Hardware Details

The prototype pH process system consists of three cylindrical chemical tanks each with a capacity of five litres. Each tank contains a base (NaOH), an acid (HCl) and the test solution whose pH has to be measured and neutralized. The three containers are made of special chemical corrosion resist glass. For proper mixing of the above mentioned three solutions another tank is used. This tank is called mixing tank. To provide uniform mixing the mixing tank contains a stirrer. This stirrer is made of fiber glass. The capacity of the mixing tank is 5 litres. A reservoir tank of capacity ten litres is provided additionally. The complete block diagram of the process is shown in Fig. 2. The stirring action is done by a permanent magnet DC Motor. The ratings of the motor are 12 V DC, torque 1kg-cm, 1500 RPM. For temperature compensation, a Resistance Temperature Detector (RTD) is provided. Polyethylene plastic are used for Piping, manual valves and fittings with sizes ranging from 1/8 to 1/4 inches.

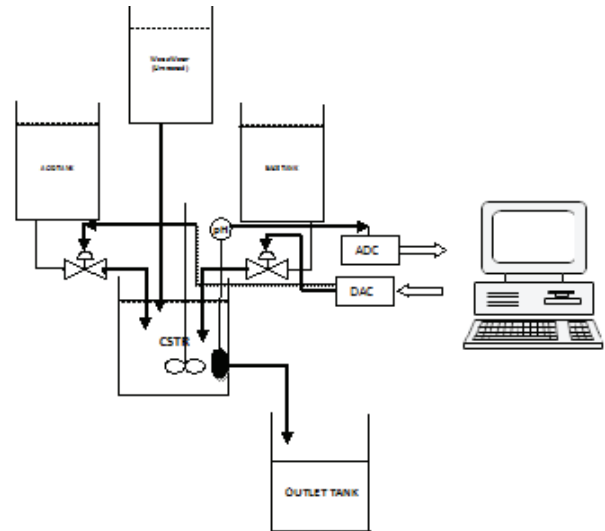

Figure 2: Overall Block Diagram of the pH prototype process

They have the property of chemical corrosion resistance. Pneumatic pressure transfer is done via Nylon tubing. Glass electrode is the type of pH measuring sensor. For regulating the acid and alkaline flow, two Equal Percentage type control valves with two way and normally closed (NC) type are used. The pressure signal 3-15 psi is used as an input to the valves. Both have a body of 1/2 inch and with a trim of 1/4 inch. Teflon is used for acid valve so as to prevent corrosion. The outputs ranging from 3 to 15 psi are provided by two current to pressure converters. LabVIEW software is used to run the process.

B. Experimental Procedure

The setup is cleaned properly before beginning the process so as to remove any contaminated material. The pH electrode sensor is cleaned and calibrated using standard buffer solutions. Using online computer, the experimental runs are achieved. The acid and base reagents are filled in their respective tanks. The interface between the computer and the process setup are verified. Power supply is switched ON only after verifying the power supply to other parts of the process. Using the LabVIEW software the setpoint i.e. the required pH in the tank is set and the SMC control also has to be selected. The process variable i.e. pH of the solution in the mixing tank is sent to the computer through the NI-DAQ input module. This information is sent in the form of the standard current signal of the range 4-20mA. The set point is compared with the pH of the solution of the mixing tank and an error signal is generated. This error signal is manipulated accordingly and a control output is generated. Using the NI-DAQ output module, the controller output is given to the current to pressure (I/P) converter. The input signal is a 4-20 mA varying current signal. An output pressure is generated for a corresponding input current in the current-to pressure converter. The pressure converted is in the range of 3-15 psi. The positioner of the acid and alkaline valves is regulated by this converted pressure. The valves

of both acid and alkaline tanks opens or closes proportionally, thereby giving the necessary quantity of the reagents to regulate the pH of the solutions in the mixing tank. The response can be viewed in graphical format on the computer.

III. CONTROLLER

Process control is an engineering stream that deals with algorithms, architectures and mechanisms for maintaining the response of a process within a specified range. Several controllers are used in process control industries to enable mass production from continuously operated processes such as power plants, oil refining industries, chemicals process industries, paper manufacturing industries and many others.

Sliding Mode Controller

The Sliding Mode Control (SMC) is a non linear control technique, which is a type of VSC. SMC exhibits high insensitivity to parameter variations and disturbances. The Sliding Mode Controller has two parts (i) a sliding surface which is stable and (ii) a corresponding control law which forces the states of the system to reach the selected surface in finite time. Sliding Mode Control is a nonlinear control method. By application of a discontinuous control signal the dynamics of the non linear system gets altered. This control signal forces the states of the system to "slide" along the cross-section of the control structures associated with that system. When subjected to actuators the main problems that are faced by controllers are the imperfections, this in turns leads to chattering, plant damage, energy loss etc. The control action in this process is an action of switching between two states. So the parameters are not affected by external variations or disturbances. The design of SMC is done by first defining the sliding surface. Equation (1) given below is representation of the Sliding Surface

$$S = \delta_s(p_1 - X) \quad (1)$$

where δ_s is a positive scalar.

δ_s represents the slope of the sliding surface .

X is the setpoint and p_1 is the pH obtained from the process.

The corresponding control law which forces the system to the sliding surface is given by

$$u = \frac{1}{\alpha_s} . C [\alpha_s . a \sqrt{z_1} - W_s \operatorname{sgn}(S_s)] \quad (2)$$

A chattering response is obtained at the output. This occurs due to the shift in the state trajectories due to the discontinuous control law. To minimize this effect a Dynamic Sliding Mode Control is applied. This decreases the chattering and limits it, thereby giving a smooth output.

IV. INTERFACING WITH THE PROCESS PLANT

In this process, pH and flow sensors are coupled, apart from the tanks, with a control and monitoring unit. As pH is sensitive to temperature compensation system is

provided to overcome effects of temperature changes. The reactor is made to operate at atmospheric pressure and temperature. The speed of the stirrer is around 1000 rpm. Pumps are provided with the inlet streams, so as to feed the reactor with corresponding solution. The acid stream used in this process is 0.1 M HCl and the base stream used is 0.1 M NaOH. The mixing tank with the stirrer acts as a Continuous Stirred Tank Reactor [CSTR]. To achieve the desired pH, the acidic and the alkaline streams are manipulated. LabVIEW software is used to design the SMC controllers. The data is primarily transmitted to the Virtual Instrument and the VI executes the program and correspondingly the amount of acid and/or base to be added is computed. This in turn is sent as a pressure signal to open or close the control valves of the acid and base stream. The experimental Setup of the process is shown in Fig. 3. The figure shows two tanks on either ends which contains Acidic and Alkaline solutions. The solution whose pH has to be regulated is seen at the centre. Also seen is the Continuous Stirred Tank Reactor [CSTR] which regulates the pH of the solution by mixing the acidic and alkaline solutions in proper proportions. Both the CSTR and the reservoir are placed below the process.

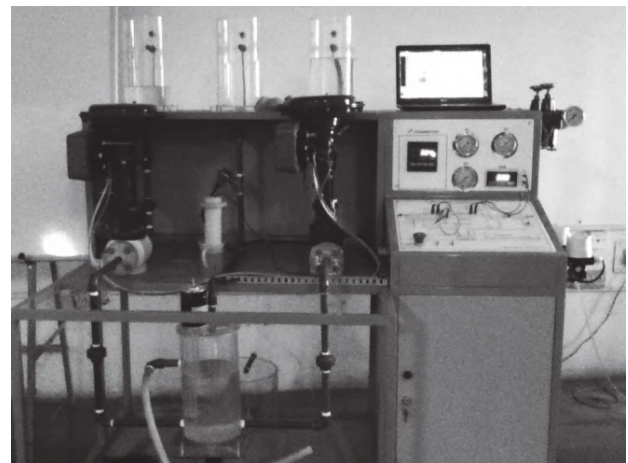

Figure 3: Prototype Experimental Setup of the pH process

V. VIRTUAL INSTRUMENT

The virtual instruments simulating the various control actions are shown. The Front Panel of the whole pH process is shown in figure 4. The controllable features of the system are indicated in it. The ability to change the pH is incorporated. The front panel is programmed in such a way that the user can use the controls on the screen in an easier and user friendly way. The front panel consists of dials, knobs, graduated tanks and graphical display.

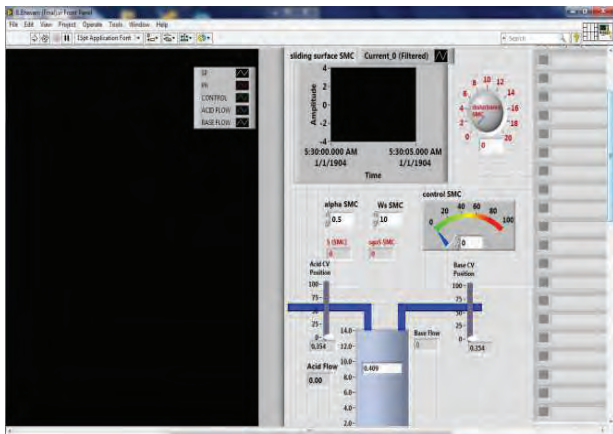

Figure 4: Front Panel of the process

VI. RESULTS

Initially the plant is cleaned to remove any contaminations or residues. The pH electrode sensor is cleaned and calibrated using buffer solutions. Each tank is filled with the respective solutions. Hydrochloric acid in the acid tank and Sodium hydroxide in the alkaline tank. The interface between the prototype process and computer is verified. The required setpoint of pH is selected using LabVIEW software. The responses are observed in both in the virtual tank and also in graphical method. A tabular format of values is obtained by importing the values to Microsoft excel at every instant. The desired pH set point is 13 which have to be maintained in the mixing tank. On application of the Sliding Mode Controller, the following responses are achieved.

Sliding Mode Controller

The pH setpoint level was set at 13. After 30 seconds the output reached the setpoint. The peak overshoot of the response was observed around ± 0.2 pH. Figure 5 shows the response of the system on the application of SMC.

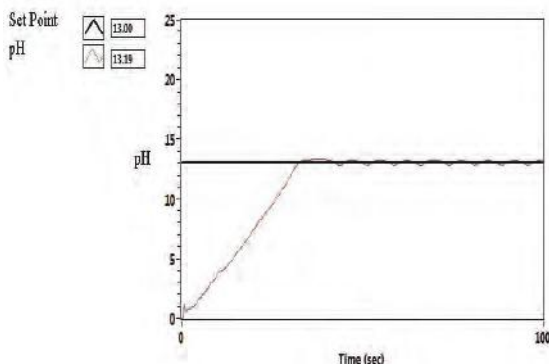

Figure 5: Graph showing response of pH due to SMC

The figure 6 shows the flow rate of acidic and alkaline solution into the tank. It is seen that a lot of chattering is observed. To minimize this effect a Dynamic Sliding mode controller can be incorporated.

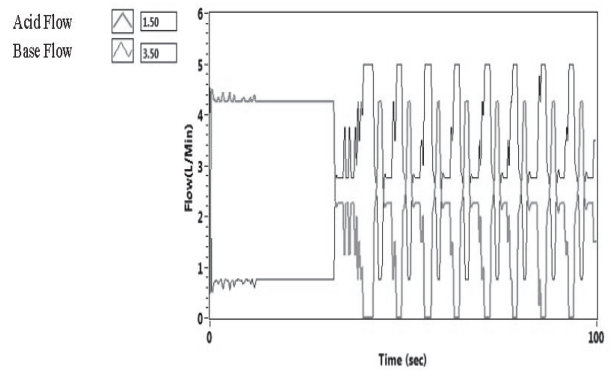

Figure 6: Graph showing the acid and base flows in the tank

VII. CONCLUSIONS

A few researches have been earlier done in this neutralization process. As LabVIEW software is used the results are more user friendly. This paper presents sliding mode control for a pH neutralization prototype process. Physico-chemical principles and fundamental laws are used to achieve process modeling of the prototype process. A mathematical modeling process is incorporated. To estimate the manipulating variables which were unknown earlier, several practical tests are carried out on the actual system. The robustness of the system was increased using the sliding mode controller. Also real time changes were incorporated satisfactorily. The chattering features of the output can be minimized by incorporating a Dynamic mode controller.

REFERENCES

- [1] S. Harivardhagini, A. Raghuram “Labview based ph control of a waste water treatment Prototype plant by incorporating PID,SMC and DSMC Controllers” i-manager’s journal on instrumentation & control engineering, vol. 3 1 no. 1 1 November 2014 - January 2015. Pages 16-22
- [2] Stephanopoulos, G., “Chemical Process Control – An introduction to theory and practice”, Prentice Hall, 2nd Edition, 1984.
- [3] Abdullah, Krsiti, Ibrahim, “A review of pH neutralization process”, IEEE Trans. On Intelligent and Advanced Systems, Vol. 2, Page Nos.: 594-598, 2012.
- [4] K.D. Yung, V.I. Utkin, “A control engineer’s guide to sliding mode control”, IEEE Trans. On control systems technology, Page Nos.328-342, 1999.
- [5] S.V.Emelyanov et.al., “On Design of Variable Structure Control Systems for control of Linear plants” Eng. Cybern., No.2, Page Nos. 69-78,1963.
- [6] S.V.Emelyanov et.al., “Theory of Variable Structure Systems”(in Russian), Moscow: Nauka, 1970.
- [7] Utkin “Sliding modes in control and optimization”, Berlin, Springer-Verlag, 1992.
- [8] Vadim Utkin and Hoon Lee, “Chattering Problem in Sliding Mode Control Systems”, ,Proceedings of the 2006 International Workshop on Variable Structure Systems Alghero, Italy, June 5-7, 2006.
- [9] C.Edwards and S.K Spurgeon ” Sliding Mode Control Theory and Applications ” Taylor and Francis Vol 7,1998.
- [10] C.Edwards and S.K Spurgeon ” Sliding Mode Control Theory and Applications ” Taylor and Francis Vol 7,1998.