

# Transmission Line Outage Detection and Identification by Communal Spider Optimization Algorithm

R.Vijay

Assoc. Professor, CVR College of Engineering/ EEE Department, Hyderabad, India

Email: vijai.mtp@cvr.ac.in

**Abstract:** The load on the power system network is proliferating along with massive inter-area transfers. Hence it is substantial to have reliable real-time information about the network parameters of the electric power system. To monitor real-time operational reliability, the network model of the system has to be updated continuously in a timely manner to reflect current system conditions. For this continuous data updating, the Phasor Measurement Units (PMUs) are deployed. PMUs measure the phase at very high speed at different locations by different devices and synchronize them with time. In manipulating the arithmetical possessions of voltage phase angle capacities attained from PMUs, this method is formulated. The proposed method detects and identifies the line outages in near real-time. In this method, outage in an unknown line is detected by using Communal Spider Algorithm (CSA) and is verified on Indian utility- 62 bus test system. Using CSA, the system performance of the power network model is optimized and the line outage is reduced.

**Index Terms:** Power system network, Line outage, PMUs, Communal Spider Algorithm.

## I. INTRODUCTION

The operational reliability of electric power system should be maintained indispensably to ensure adequacy and security of the system. As far as India is concerned, ensuring the reliability of the power system plays a significant role to maintain the security of power transmission. The major factor affecting the reliability of the system is line outages. Earlier detection of overloading or outage in transmission line may result in prevention of system blackouts [1]. In order to monitor the operational reliability of the power system, a network exemplary of the structure acquired offline which comprises the power transmission system topology considerations is used. Owing to the point that there is an inadequate simultaneous allocation of SCADA or state estimator statistics in India, these power network topology limitations are not generally conversant.

The fallacious telemetry records of the power system network parameters will contribute to overloading of certain lines and may lead to blackouts ultimately. In order to apprise the exemplary employed in the functional reliability analysis for an appropriate way to replicate current coordination circumstances, the PMUs are deployed. The PMU is a modern, fast transducer that provides coordinated phasor measurements of voltages & currents from extensively spread places of the whole power grid. That measures the voltage and current phasor at precise high speed, typically thirty measurements per second [2]. These measurements are

obtained from diverse positions by diverse maneuvers and are time-coordinated [3].

Many approaches to detect line outage by identifying the change in network topology errors by using a state estimation technique have been proposed in [4], [5], [6] and [7]. With the far-flung deployment of PMUs, various techniques like hypothesis testing [8], sparse vector estimation [9] and mixed-integer nonlinear optimization [10] have been developed. These methods consider that the line outage as loss of line is in out of service even after the fault detection. Method of persistent line outage detection with PMUs was developed with Quickest Change Detection (QCD) algorithm [11].

This paper attempts to apply the procedure of Communal spider algorithm (CSA) [12] to detect line outage efficiently and optimize the system performance. Many swarm intelligent algorithms have been proposed mimicking the behavior of insect or animal groups prevailing in nature. CSA is formulated by miming the foraging behavior of communal spiders. In CSA, [13] the searching information is propagated among communal spider species through vibrations by which the loss is attained. Hence they distinguish the vibrations generated by the prey with the ones generated by own species. This quality may contribute to the optimum search in some complex multimodal optimization problems which makes CSA preferable over other swarm intelligent techniques. Also, the statistics produced and proliferated through the vibrations are the existing locations in its place of the preminent locations that might diverge significantly in their exploration. This distinctive penetrating arrangement and its causal social animal foraging stratagem along with the Information Sharing (IS) foraging typical add the complete enactment of CSA when compared to other evolutionary algorithms.

In this proposed method, the voltage phase angle quantities acquired from PMU's are used to sense and recognize line outages in simultaneous. The incremental change in net power injections at each bus is modeled as independent random variables. Any variations in the probability distribution of these random variables are due to the random fluctuations with the generation and load. Probability distribution of net power injections and voltage angle measurements are related by a linear mapping using incremental small signal power flow model. Whenever an outage occurs in a line, the probability distribution of random variable changes. The objective is to notice this modification in the distribution system as speedy as probable by using the

CSA. In this projected technique the point that line outage is tenacious is too amalgamated.

## II. PROBLEM FORMULATION

### A. Power system transmission line model prior to outage

Consider a power system with S nodes, each corresponding to a bus and there exists a transmission line between buses a and b such that a, b ∈ S.

- Let  $V_i(j)$ - Voltage of  $i^{th}$  bus
- $\phi_i(j)$  - Phase angle of the corresponding  $i^{th}$  bus
- $P_i(j)$ & $Q_i(j)$  – Injected active & reactive power of  $i^{th}$  bus at the time instant  $\tau$ , where  $\tau = j\Delta\tau$  ;  $j=0,1,2,\dots$ ;  $\Delta\tau>0$ .

The disparities in both the injected active and reactive power in  $i^{th}$  bus amongst braces of successive sampling time  $j\Delta\tau$  and  $(j+1)\Delta\tau$  is set as  $\Delta P_i[j] = P_i[j+1] - P_i[j]$  and  $\Delta Q_i[j] = Q_i[j+1] - Q_i[j]$  respectively. Similarly, the variations in voltage and phasor angle in bus i between pairs of consecutive sampling times  $j\Delta\tau$  and  $(j+1)\Delta\tau$  is given by  $\Delta V_i[j] = V_i[j+1] - V_i[j]$  and  $\Delta\phi_i[j] = \phi_i[j+1] - \phi_i[j]$  respectively. It is considered that the synchronized voltage phasor measurements in all busses are collected using PMU's each  $\Delta\tau$  unit of time. Assuming  $\Delta V_i[j]$  and  $\Delta\phi_i[j]$  are sufficiently small,  $\Delta P_i[j]$  and  $\Delta Q_i[j]$  is approximated with first order Taylor's series expansion as

$$\begin{bmatrix} \Delta P[j] \\ \Delta Q[j] \end{bmatrix} = \begin{bmatrix} J_1[j] & J_2[j] \\ J_3[j] & J_4[j] \end{bmatrix} \begin{bmatrix} \Delta\phi[j] \\ \Delta V[j] \end{bmatrix} \quad (1)$$

Normally power transmission lines have high (X/R) ratio, i.e. they are mostly reactive. The change in real power is more sensitive to change in phasor angle and less sensitive to change in voltage. Also change in reactive power is more sensitive to change in voltage and less sensitive to change in angle. Hence  $J_2$  &  $J_3=0$  and the equation becomes  $\Delta P[j] \approx J_1[j]\Delta\phi[j]$ . Further the following DC assumptions are considered,

1. The system is taken as lossless.
2. The voltage at all buses,  $V_i[j]=1$ p.u. for all  $i \in S, j$
3. The difference in phasor angle of voltage  $\phi_a[j] - \phi_b[j] \ll 1$  for all j and a, b ∈ S

In these assumptions, the matrix  $J_1[j]$  becomes the negative imaginary part of the considered network admittance matrix created, though abandoning line resistance. Hence  $J_1[k] = NP_0$  for all i under the same topology. Therefore

$$\Delta P[j] \approx NP_0 \Delta\phi[j] \quad (2)$$

The items in  $\Delta P[j]$  are exhibited as self-governing and indistinguishably disseminated with a joint Gaussian probability density function, i.e.  $\Delta P[j] \sim \mathcal{N}(0, \Sigma)$ . The equation is rewritten as  $\Delta\phi[j] \approx N_0 \Delta P[j]$ , where  $N_0 = NP_0^{-1}$ . Thus the distribution of system prior to line outage is given by

$$\Delta\phi[j] \sim f_0 \text{ where } f_0 = \mathcal{N}(0, N_0 \Sigma N_0^T) \quad (3)$$

### B. Power system transmission line outage model

Let at time  $\tau = \tau_f$  an outage occurs in line (a, b). In this method it is assumed that line losses would not cause islands to practice in the post-event system. The fundamental graph represents the power system gets connected. Moreover, the line loss is presumed as tenacious event, i.e., line is not reverted to service in the period is considered for line outage detection as in [11].

1) Persistent change detection in phasor angle:

As stated above a persistent outage occurs in line (a,b) at time  $\tau = \tau_f$  where  $(\beta-1)\Delta\tau \leq \tau_f \leq \beta\Delta\tau$  for some random time  $\beta > 0$ . For  $\tau_j \geq \beta$ ,  $N_0$  matrix changes to  $N_{(a,b)}$ . Hence the post outage equation is

$$\Delta\phi[j] \approx N_{(a,b)} \Delta P[j], \text{ for } j \geq \beta \quad (4)$$

The post-outage matrix  $NP_{(a,b)}$  is sum of pre-outage matrix  $NP_0$  and some perturbation matrix  $\Delta NP_{(a,b)}$ . So  $NP_{(a,b)} = NP_0 + \Delta NP_{(a,b)}$ . The non-zero terms in matrix  $\Delta NP_{(a,b)}$  are  $\Delta NP_{(a,b)}[a,a] = \Delta NP_{(a,b)}[b,b] = -\Delta NP_{(a,b)}[a,b] = -1/X_{(a,b)}$ , where  $X_{(a,b)}$  is the imaginary part of the impedance of the outaged line [15]. Hence  $\Delta NP_{(a,b)}$  is expressed as  $\Delta NP_{(a,b)} = -\frac{1}{X_{(a,b)}} v_{(a,b)} v_{(a,b)}^T$ , where  $v_{(a,b)}$  is a vector then

(a-1)<sup>th</sup> item is taken as 1, (b-1)<sup>th</sup> item is engaged to -1 and rest other items is articulated to 0. Therefore

$$\Delta\phi[j] \approx N_{(a,b)} \Delta P[j], \text{ for } j \geq \beta \quad (5)$$

Where  $N_{(a,b)} = NP_{(a,b)}^{-1} = N_0 + \Delta N_{(a,b)}$ . Thus after the outage of line (a,b),

$$\Delta\phi[j] \sim f_{(a,b)}^{pc} \quad (6)$$

where  $f_{(a,b)}^{pc} = \mathcal{N}(0, N_{(a,b)} \Sigma N_{(a,b)}^T)$  for  $j \geq \beta$

If line (a,b) is not restored, this change is persistent. To avoid repeated matrix inversions for each possible line outage matrix inversion lemma is used.

$$\Delta N_{(a,b)} = m1_{(a,b)} m2_{(a,b)} m2_{(a,b)}^T \quad (7)$$

where  $m1_{(a,b)} = 1/(X_{(a,b)} - v_{(a,b)}^T NP_0^{-1} v_{(a,b)})$  and  $m2_{(a,b)} = NP_0^{-1} v_{(a,b)}$ .

2) Instantaneous change detection in phasor angle:

If the line outage occurs at time  $\tau = \tau_f$ , where  $\beta\Delta\tau \leq \tau_f < (\beta+1)\Delta\tau$ , an instantaneous change that affects only one incremental sample  $\Delta\phi[\beta] = \phi[\beta+1] - \phi[\beta]$  is also considered. Since  $\phi[\beta]$  is got from pre-outage system while  $\phi[\beta+1]$  is got from post-outage system, the incremental change at  $j=\beta$ ,  $\Delta\phi[\beta]$  is not given in the previous model. Prior to line outage the real power injection in all buses i,  $i \in S$ , is given by

$$P_i[j] = p_i[j], \text{ } j \leq \beta \quad (8)$$

After outage of line (a,b) and assuming the outage is persistent, the real power equation in post-outage scenario is

$$P_i[j] = p_i'[j], \text{ } j \geq \beta+1 \quad (9)$$

(3)

(4) The incremental variation of whole active power injection amongst the two PMU trials, directly prior to and subsequent line outage, i.e., between  $j=\beta$  and  $j=\beta+1$  is stated as  $\Delta P_i[\beta] =$

$P_i[\beta+1]- P_i[\beta]$ . Substituting equations (8) and (9) the equation obtained is  $\Delta P_i[\beta] = p_i'[\beta+1]- p_i[\beta]$ . Adding and subtracting  $p_i'[\beta+1]$  to the above equation

$$\Delta P_i[\beta] = \Delta P_i^{ic}[\beta] + \Delta P_i^{pc}[\beta] \quad (10)$$

where  $\Delta P_i^{ic}[\beta] = p_i'[\beta+1]- p_i[\beta+1]$  and  $\Delta P_i^{pc}[\beta] = p_i[\beta+1]- p_i[\beta]$ . As derived previously  $\Delta P_i^{pc}[\beta]=p_i[\beta+1]- p_i[\beta]$ .  $\Delta P_i^{ic}$  component is determined next. Using the DC estimates considered above, the line flow through the transmission line (a,b) below the pre-outage network topology is specified as

$$P_{(a,b)}[\beta+1] \approx \frac{1}{X_{(a,b)}} (\Phi_a[\beta+1]-\Phi_b[\beta+1]) \quad (11)$$

The line outage is exhibited through accumulating two power instillations to the system, one at every termination of the transmission line to remain plummeted. Hence the outage of line (a,b) is simulated by adding  $P_{(a,b)}[\beta+1]$  and  $-P_{(a,b)}[\beta+1]$  at buses a and b respectively. Define  $\Delta P^{ic}$  as an (S-1) dimensional vector, the (a-1)<sup>th</sup> and (b-1)<sup>th</sup> entries of which are  $P_{(a,b)}[\beta+1]$  and  $-P_{(a,b)}[\beta+1]$  respectively, and all other entries are 0.  $\Delta P^{ic}$  is obtained as

$$\Delta P^{ic}[\beta] = P_{(a,b)}[\beta+1]v_{(a,b)} \quad (12)$$

where  $v_{(a,b)}$  is a vector in that (a-1)<sup>th</sup> item is taken as 1, (b-1)<sup>th</sup> item is taken as -1 and further items is tends to 0. Combining the expressions for  $\Delta P_i^{ic}[\beta]$  and  $\Delta P_i^{pc}[\beta]$  and after rearrangement  $\Delta\Phi$  is got as

$$\Delta\Phi[\beta] \approx N_0(\Delta P[\beta]-P_{(a,b)}[\beta+1]v_{(a,b)}) \quad (13)$$

This indicates that the mean of  $\Delta\Phi[\beta]$  is  $-N_0P_{(a,b)}[\beta+1]v_{(a,b)}$  is not simply 0 (as in all sample  $j<\beta$ ). Thus at  $j=\beta$ ,

$$\Delta\Phi[\beta] \sim f_{(a,b)}^{ic} \quad (14)$$

where  $f_{(a,b)}^{ic} = \mathcal{N}(-N_0P_{(a,b)}[\beta+1]v_{(a,b)}, N_0\Sigma N_0^T)$

### 3) Summary of line outage problem:

Suppose an outage involving line (a,b) occurs at time  $\tau_f$  between PMU sampling times  $\tau_1$  and  $\tau_2$  then,

$$\Delta\Phi[j] \approx \begin{cases} N_0\Delta P[j], & j \leq \beta-1 \\ N_{(a,b)}\Delta P[j], & j \geq \beta+1 \end{cases}$$

Here the probability density function of  $\Delta\Phi[j]$  is

$$\Delta\Phi[j] \sim \begin{cases} f_0, & j \leq \beta-1 \\ f_{(a,b)}^{pc}, & j \geq \beta+1 \end{cases}$$

At time instant  $j=\beta$ , two cases are considered depending on  $\tau_1$  and  $\tau_2$ .

(i) If  $\tau_1=(\beta-1)\Delta\tau$  and  $\tau_2=\beta\Delta\tau$

$$\Delta\Phi[j] \approx N_{(a,b)}\Delta P[j]$$

(ii) If  $\tau_1= \beta\Delta\tau$  and  $\tau_2= (\beta+1)\Delta\tau$

$$\Delta\Phi[j] \approx N_0(\Delta P[\beta]-P_{(a,b)}[\beta+1]v_{(a,b)})$$

Here the probability density function of  $\Delta\Phi[\beta]$  is

$$\Delta\Phi[\beta] \sim \begin{cases} f_{(a,b)}^{pc}, & \tau_1=(\beta-1) \\ f_{(a,b)}^{ic}, & \tau_2=\beta\Delta\tau \end{cases}$$

### 4) Probability of false isolation

Probability of false isolation denotes the probability that the outage in transmission line (a,b) is deceptively recognized as outage in next corresponding transmission line. It is used as a metric to device the efficacy of the line outage recognition and considered algorithm.

## III. PROPOSED LINE OUTAGE DETECTION METHOD USING CSA

### A. Spider and vibration

By using CSA for line outage detection, the search space of the problem is formulated as hyper-dimensional spider web  $S$  as IS model [16]. The web also serves as transmission media of vibrations generated by spiders. Each spider  $i$  of the population  $pop$  in the web holds a memory for storing information for parameters used in CSA such as position  $P_i(t)$ , fitness value  $f(P_i(t))$ , where  $t$  is the iteration index and  $f(x)$  is the objective function, target vibration  $V_i^{tar}$  and dimension mask to guide the movement.

Spiders are extremely sensitive to the vibrations in the web. When a spider travels to a different position, it produces a vibration that disseminated on the web. Every vibration grasps the evidence of lone spider and further the others acquire the evidence upon reception on the vibrations. The spiders generate vibrations at their position using the expression in eqn.15. Two main properties are used to denote a vibration, namely, the source position and the source intensity of the vibration. These two properties are linked to the line outage scenario for identifying the position of outage. The intensity of vibration is obtained by expression

$$I_i = \log\left(\frac{I}{f(P_i)-C} + 1\right) \quad (15)$$

Where  $P_i(t)$  is the position of spider  $i$  and  $C$  is surely a small constant. After a vibration is generated, when propagated over the web it attenuates. Vibration attenuation over distance is given by (16)

$$I_i^D = I_i \times \exp\left(-\frac{D}{m_\sigma \times r_a}\right) \quad (16)$$

Where  $D$  - distance,  $m_\sigma$  - mean of standard deviation of the spiders location over all dimensions and  $r_a$  - rate of attenuation (regulating factor).

### B. Computational pattern of CSA

The whole computational pattern of CSA involves three main phases that includes initialization phase, iteration phase and final phase. As the name states, initialization phase involves initialization of the objective function  $f(x)$ , solution space  $S$ , population of spiders  $pop$  and memory and the values for the parameters used in CSA.

Iteration phase is the most notable phase and consists of sub-steps comprises of fitness evaluation, vibration generation, mask changing, random walk and constraint handling. In fitness evaluation the fitness values of all artificial spiders are calculated. For each spider, the iteration

fitness function is evaluated once. Subsequently, every fitness values are assessed; every spider will engender a vibration in its present location by means of eqn.15. The vibrations are disseminated in the spider web which is given in eqn.16 and received by all other spiders. When the strongest vibration is obtained, it is compared with the threshold value. If the constraint is violated, the position from where the strongest vibration is got is reported as the line outage spot.

*C. Pseudocode of modified CSA for line outage detection problem*

```

Assign the CSA parameters.
Generate the spiders population (pop) & consign
reminiscence for each.
Set  $V_i^{tar}$  for every pop
for each spider i in pop do
    Evaluate the fitness value
    Generate a vibration at the spider's position
    Calculate the intensity of vibrations
    generated by all spiders
    Select the strongest vibration  $V_i^{stng}$ 
    if  $V_i^{stng} \geq V_i^{th}$ 
        Report the position of strongest
        vibration  $V_i^{stng}$ 
    end if
end for
    
```

**IV. RESULTS AND DISCUSSION**

The CSA algorithm is tested on Indian utility- 62 bus test system and the results obtained are discussed below. The one line diagram of the system is shown in figure 1. This test system contains 62 Bus, 89 Transmission lines, 11 Transformers, 19 Generators and 32 Loads. The system data are taken from the reference [14]. The base is 100 MVA.

The probability of false isolation is a major problem that is encountered in the identification of the line outages in the system. With CSA, which finds solutions based on current values only, this problem is addressed and has been reduced. The table below shows false isolation probability obtained via simulation for single line outages in the test system at a particular hour of the day.

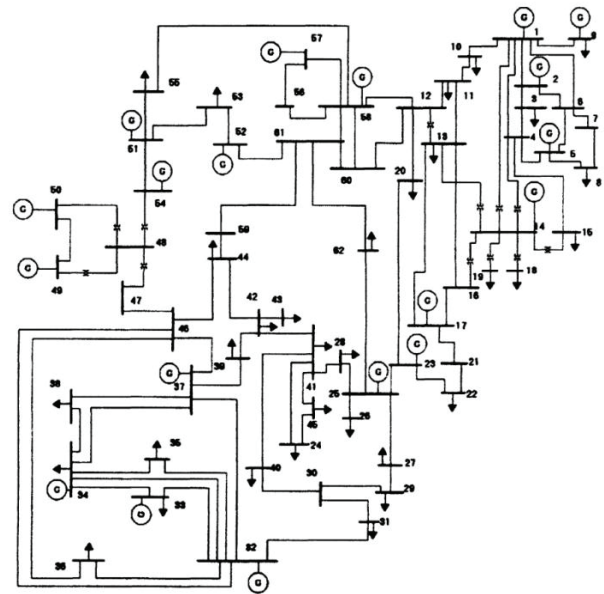

Figure 1. One line diagram of Indian utility- 62 bus test system

MATPOWER [17] simulation tool is used to obtain the voltage angles repeatedly by solving AC power flow, with each step *j* analogous to artificial power instillation profiles created using  $P_i[j] = P_i^0[j] + \sigma v[j]$ , using  $\sigma = 0.03$ . Suppose these random variations are non-simultaneous, then,  $\Sigma$  represents the transverse matrix with every diagonal access taken as 0.0018.

To pretend the most awful circumstance, then the detection delay  $\beta = 1$  is preferred. The graph in the figure 2, plots the detection delay time with respect to mean time to false alarm for each four hour a day.

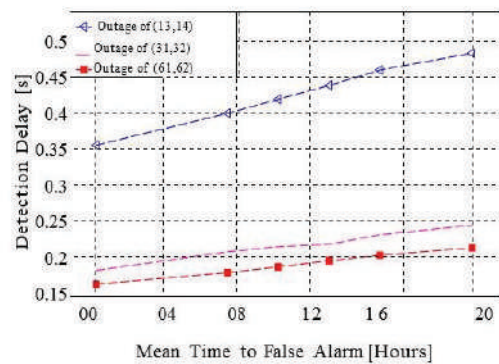

Figure 2. Typical detection delay vs despicable time to initiate false alarm for Indian utility- 62 bus test system.

As it is seen from the Table 1, the probability of false isolation has been considerably reduced. Thus line outage is distinctly identified without much effort and mathematical computations.

TABLE I.  
PROBABILITY OF FALSE ISOLATION OBTAINED VIA SIMULATION FOR SINGLE  
LINE OUTAGE IN INDIAN 62-BUS TEST SYSTEM

Line outage	Time in Hours					
	00	04	08	12	16	20
Line (13, 14)	0.0002	0	0.0023	0.0044	0.0050	0.0088
Line (31, 32)	0	0.0035	0.0010	0	0.0040	0.0055
Line (61, 62)	0	0	0.0035	0	0.0012	0.0020

## V. CONCLUSIONS

In this paper a method to detect and identify transmission line outages in near real-time is proposed. The statistical properties of phasor measurements of voltage and current obtained from PMUs are used to formulate the line outage problem. In addition, this paper attempts and introduces the use of CSA in the problem of line outage detection. By using optimization technique, the complex computations are reduced and system performance is improved. The above method assumes PMUs are available at all buses which is practically very difficult. Hence the method has to be modified for PMUs at desired locations and at the same detect the line outage optimally. This method can be extended to identify the double line outages with multiple constraints to optimize the system performance.

## REFERENCES

- [1] Report on grid disturbance on 30<sup>th</sup> July and 31<sup>st</sup> July 2012. Available:[http://www.cercind.gov.in/2012/orders/Final\\_Report\\_Grid\\_Disturbance.pdf](http://www.cercind.gov.in/2012/orders/Final_Report_Grid_Disturbance.pdf)
- [2] Z. Dong and P. Zhang, *Emerging Techniques in Power System Analysis*. Springer-Verlag, 2010.
- [3] A.G.Phadke, "Synchronized phasor measurements in power systems," *IEEE Comput. Appl. Power*, vol. 6, no. 2, pp. 10–15, 1993.
- [4] K. Clements and P. Davis, "Detection and identification of topology errors in electric power systems," *IEEE Transactions on Power Systems*, vol. 3, no. 4, pp. 1748–1753, 1988.
- [5] F. Wu and W.-H. Liu, "Detection of topology errors by state estimation [power systems]," *IEEE Transactions on Power Systems*, vol. 4, no. 1, pp. 176–183, 1989.
- [6] N. Singh and H. Glavitsch, "Detection and identification of topological errors in online power system analysis," *IEEE Transactions on Power Systems*, vol. 6, no. 1, pp. 324–331, 1991.
- [7] F. Alvarado, "Determination of external system topology errors," *IEEE Transactions on Power Apparatus and Systems*, vol. PAS-100, no. 11, pp. 4553–4561, 1981.
- [8] J. E. Tate and T. J. Overbye, "Line outage detection using phasor angle measurements," *IEEE Transactions on Power Systems*, vol. 23, no. 4, pp. 1644–1652, 2008.
- [9] H. Zhu and G. B. Giannakis, "Sparse overcomplete representations for efficient identification of power line outages," *IEEE Transactions on Power Systems*, vol. 27, no. 4, pp. 2215–2224, 2012.
- [10] R. Emami and A. Abur, "External system line outage identification using phasor measurement units," *IEEE Transactions on Power Systems*, vol. 28, no. 2, pp. 1035–1040, 2013.
- [11] Chen, Y.C., Banerjee, T., Domínguez-García, A.D. and Veeravalli, V.V., "Quickest line outage detection and identification," *IEEE Transactions on Power Systems*, 31(1), pp.749-758, 2016.
- [12] James, J.Q. and Li, V.O., "A social spider algorithm for global optimization," *Applied Soft Computing*, 30, pp.614-627, 2015.
- [13] R.Vijay, R. AnrutJaffrin and C. S. Ravichandran. "Optimal placement and sizing of solar constructed DG using SSO technique," *International Journal of Computer Science Trends and Technology*, vol.4, no. 3, pp.333-342, 2016.
- [14] R.Vijay and V. Priya. "Anti-Islanding Protection of Distributed Generation Based on Social Spider Optimization," *International Journal of Advanced Engineering Research and Science (IJAERS)*, vol.4, no. 6, 2017.
- [15] A. Wood and B. Wollenberg, *Power Generation, Operation and Control*, New York: Wiley, 1996.
- [16] R. Gnanadass, "Optimal Power Dispatch and Pricing for Deregulated Power Industry," Ph.D. Dissertation, Department of Electronics and Communication Engineering, Pondicherry University, India, Mar. 2005, [Accessed Mar. 22, 2015]. [Online]. Available:<http://dspace.pondiuni.edu.in/jspui/bitstream/pdy/498/1/T3248.pdf>
- [17] R. D. Zimmerman, C. E. Murillo-Sánchez, and R. J. Thomas, "Matpower: Steady-state operations, planning and analysis tools for power systems research and education," *IEEE Transactions on Power Systems*, vol. 26, no. 1, pp. 12–19, 2011.